

OUR EQUIPMENT CLEANS WATER



WATER
INCORPORATED

677 Day Lily Place
Acworth, GA 30102-8119
P(770) 924-9320 • F(770) 924-9321
sales@waterinc.biz

Since 1975 **Water Incorporated** has provided waste water treatment systems and equipment for both domestic and industrial applications. Our expertise in the purchase of state-of-the-art components and our flexibility and knowledge in the design and execution of the most efficient and cost-effective solutions to waste water management ensure the continued satisfaction of our clientele.



Our package waste water treatment systems provide the adaptability to produce the quality effluent specified by any application requirement. **Water Incorporated** can furnish easily relocatable or permanent package systems of durable construction and economical operation.

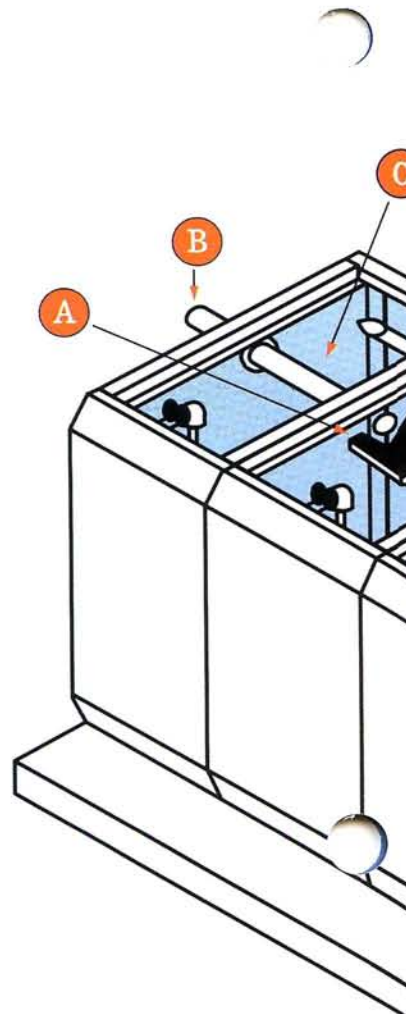

BASIC STEPS IN TREATMENT

EQUALIZATION OPTIONAL

Protects from hydraulic surges during peak flows and backwash from tertiary filter.

DIGESTER

Stabilization of excess sludge for ultimate disposal.

AERATOR

Waste water in the presence of air is broken down by microbial action into water, carbon dioxide and ash.

CHLORINATION

While not basic to a treatment system, the addition of chlorine to the effluent is generally included for disinfection.

CLARIFIER

Separation of solids from the liquid.

TERTIARY TREATMENT OPTIONS

Where a high degree of treatment is required. Water Incorporated has a complete line of tertiary treatment systems available.

PACKAGE PLANT COMPONENTS

The concept of the **Water Incorporated** Package Plant is the ability to supply an extended aeration system, along with blower units, controls, diffusers and all other ancillary equipment to a customer as a complete package ready for easy installation. Applied in locations requiring domestic waste water treatment but unable to connect to an existing municipal sewer system.

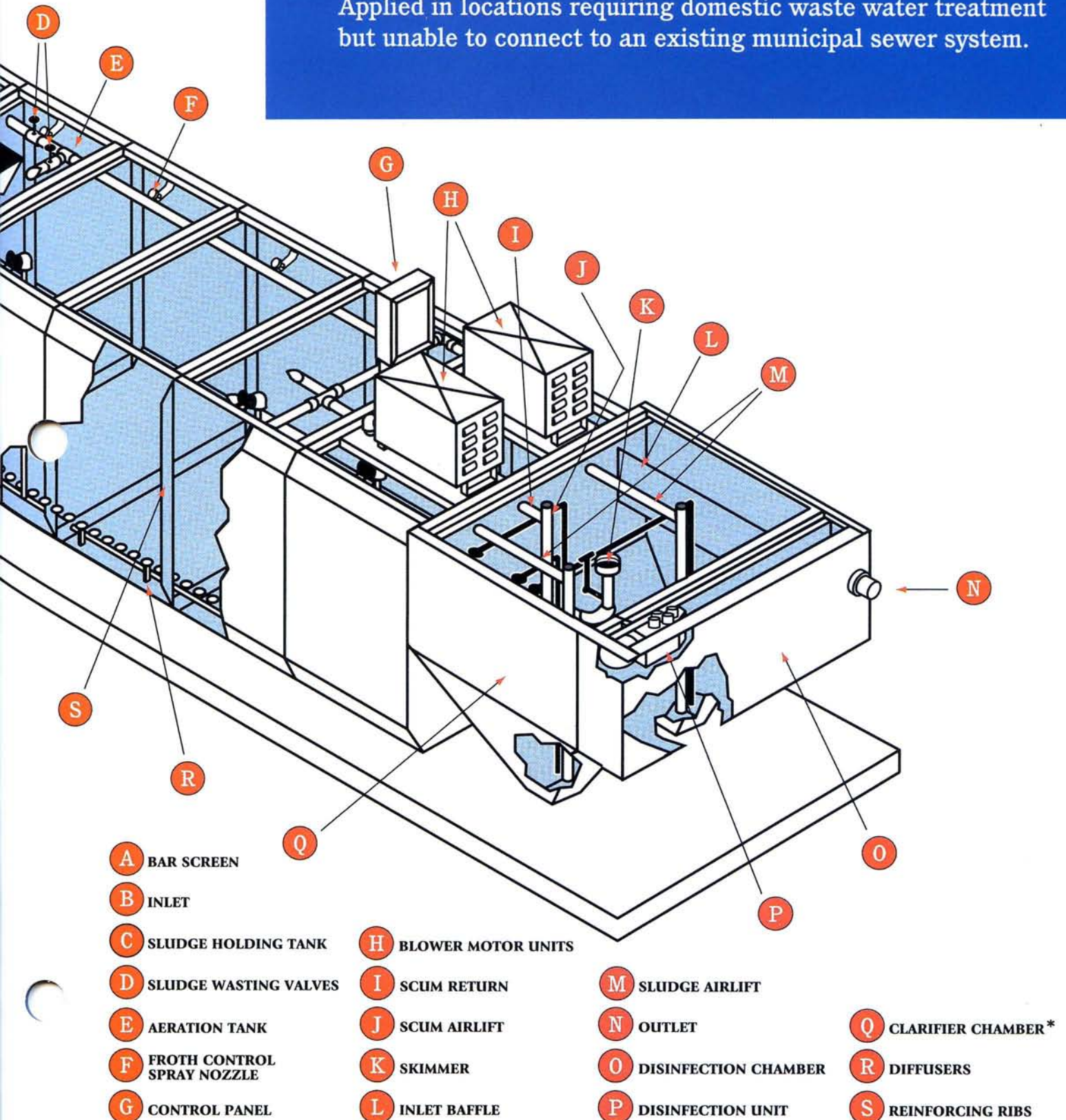

All stainless steel package plant



Double wide with access stairway



Typical blower assembly

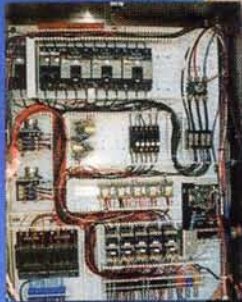

Typical package plant control panel



Available in a broad range of capacities, our principal lines include:

- *EXTENDED AERATION*
- *COMPLETE MIX*
- *CONTACT STABILIZATION*

WATER INC. factory-built and assembled PACKAGE PLANT systems feature individual housings for controls, motor and blower assemblies and state-of-the-art electrical components.

Ask your WATER INC. representative for further information concerning our unique optional features and our other wastewater treatment systems.

Your Water Inc. Representative is:



OUR EQUIPMENT CLEANS WATER

